



# ACME WIDGET

## 2010/2011 Business Plan

*The attached "Goal Tree" is the culmination of approximately 18 hours of comprehensive, focused business planning using 3GoodQuestion's "Question-Based Planning" process.*

*The business plan and goal tree show how everyone in your company can all work together to achieve something great; it makes your direction and priorities clear to all involved.*

*The goal tree is designed to be delivered in a variety of ways for distribution and presentation.*

- 8 1/2" x 11" printable PDFs
- Large poster size
- Online (Intranet)

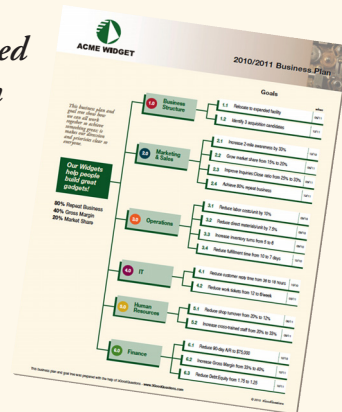

A leader should be proud to communicate their plan to all their stakeholders: a goal tree is a proven alternative to bulky "strategic plans." Call Derrick Van Mell at 608-260-9300 to learn more.



Goals

This business plan and goal tree show how we can all work together to achieve something great; it makes our direction and priorities clear to everyone.

**Our Widgets help people build great gadgets!**

80% Repeat Business  
40% Gross Margin  
20% Market Share

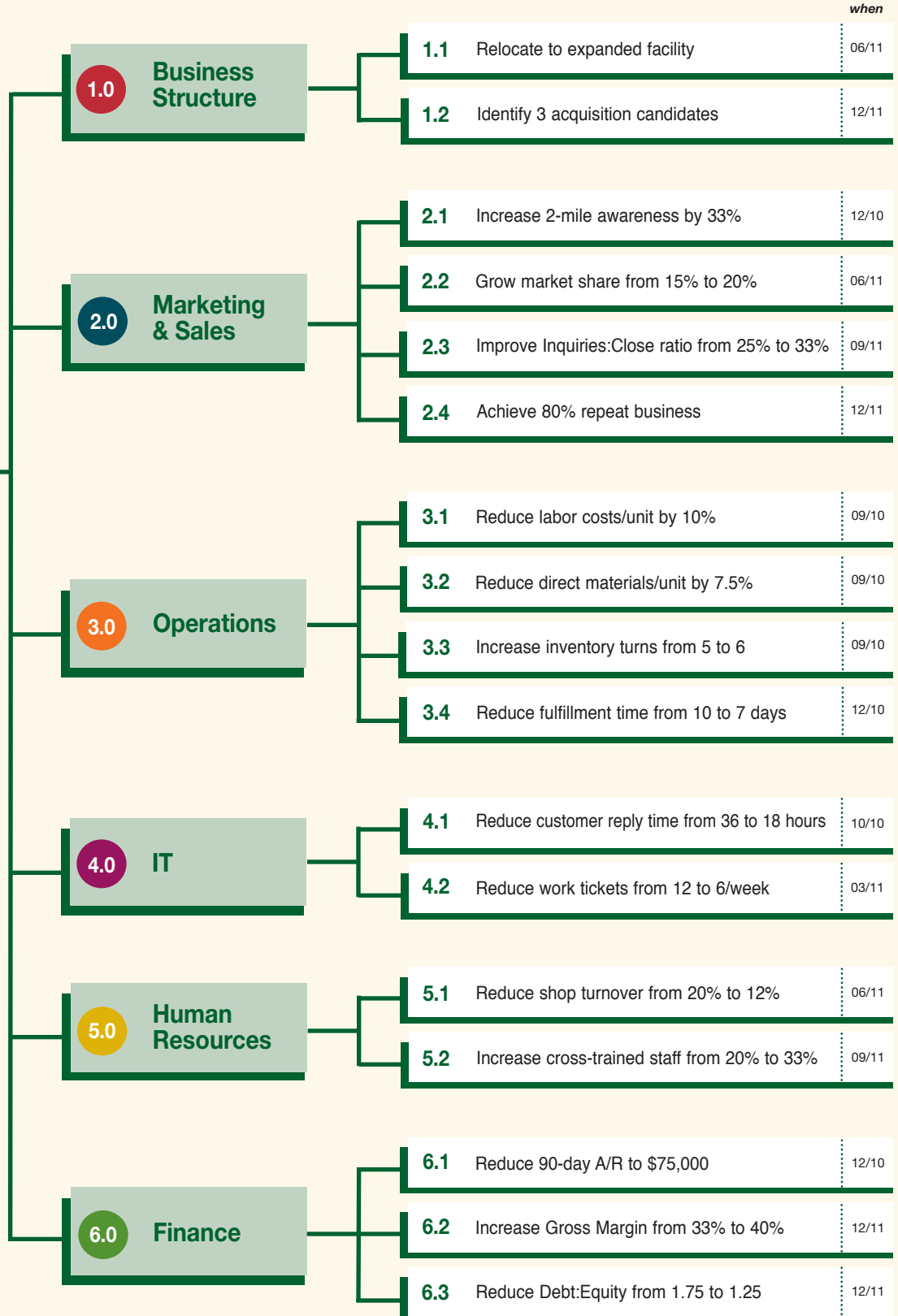



Business Structure Goals

Tasks

*This is one branch of our goal tree and business plan for 2010/2011. It shows how we depend on each other to reach our common goals.*

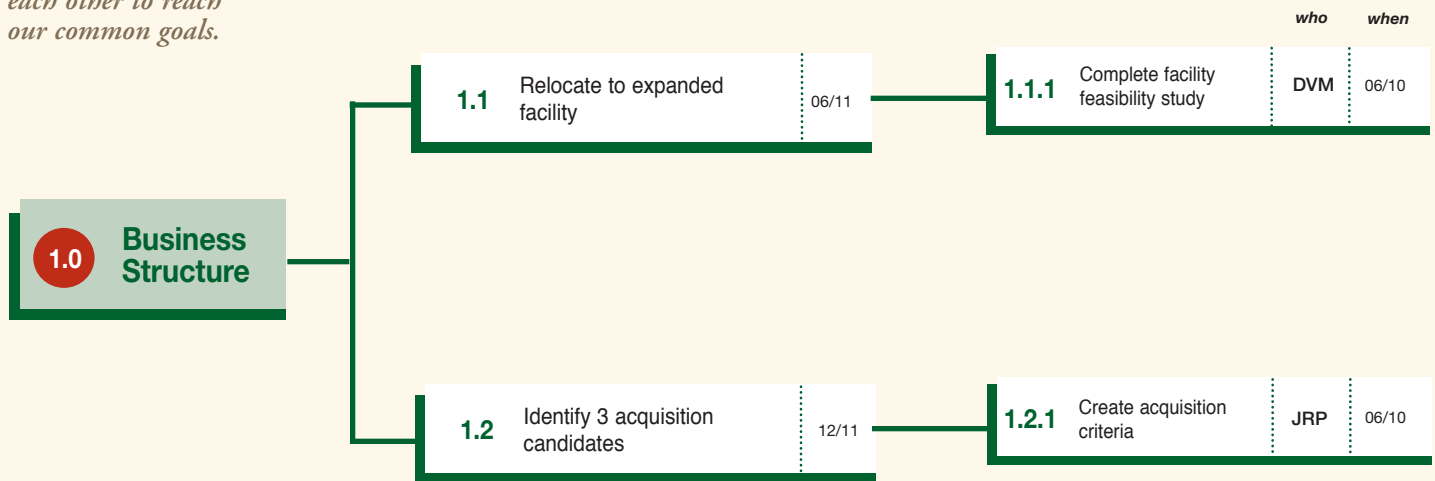



This is one branch of our goal tree and business plan for 2010/2011. It shows how we depend on each other to reach our common goals.

2.0 Marketing & Sales

Marketing & Sales Goals

Tasks

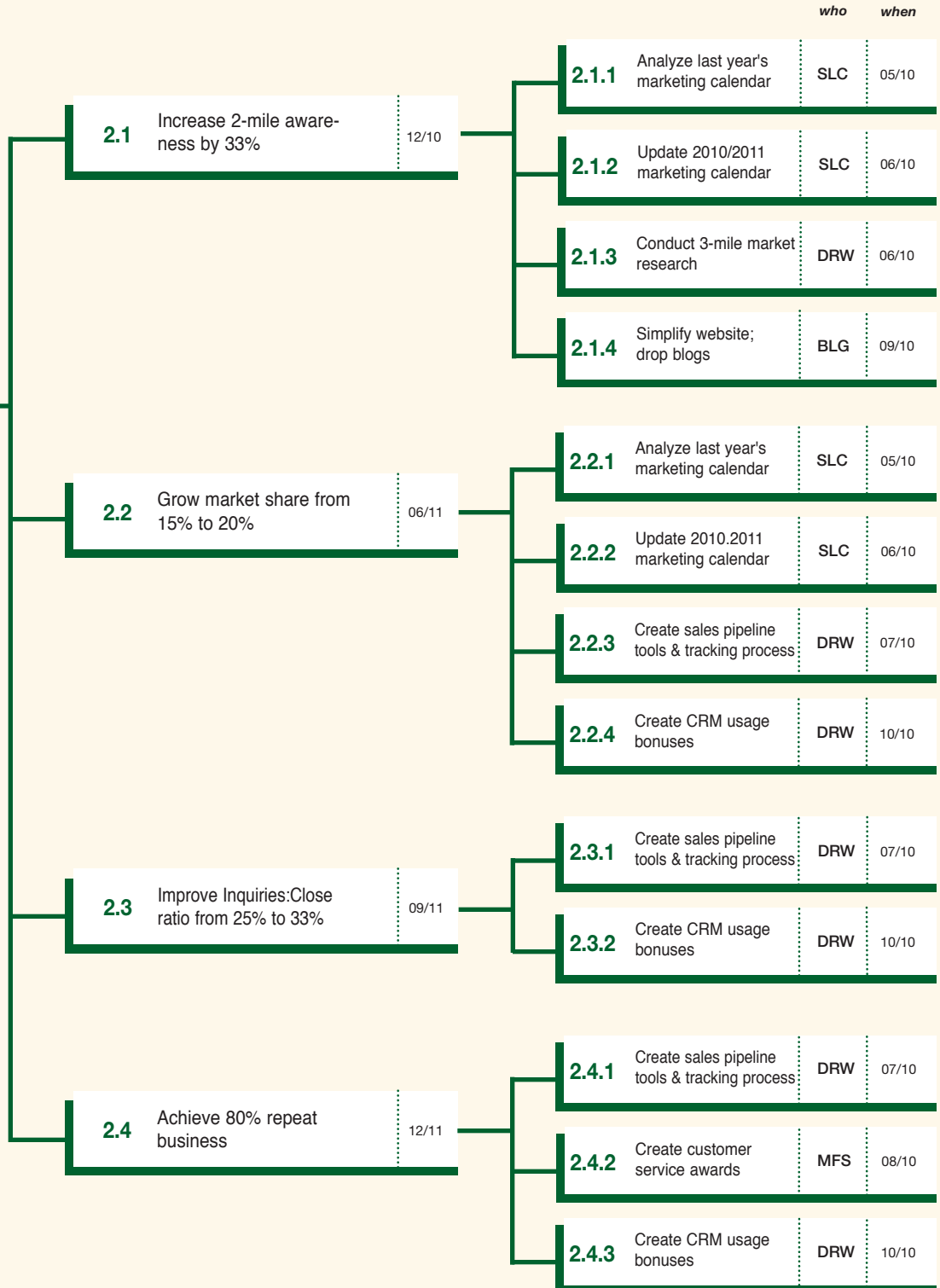



Operations Goals

Tasks

This is one branch of our goal tree and business plan for 2010/2011. It shows how we depend on each other to reach our common goals.

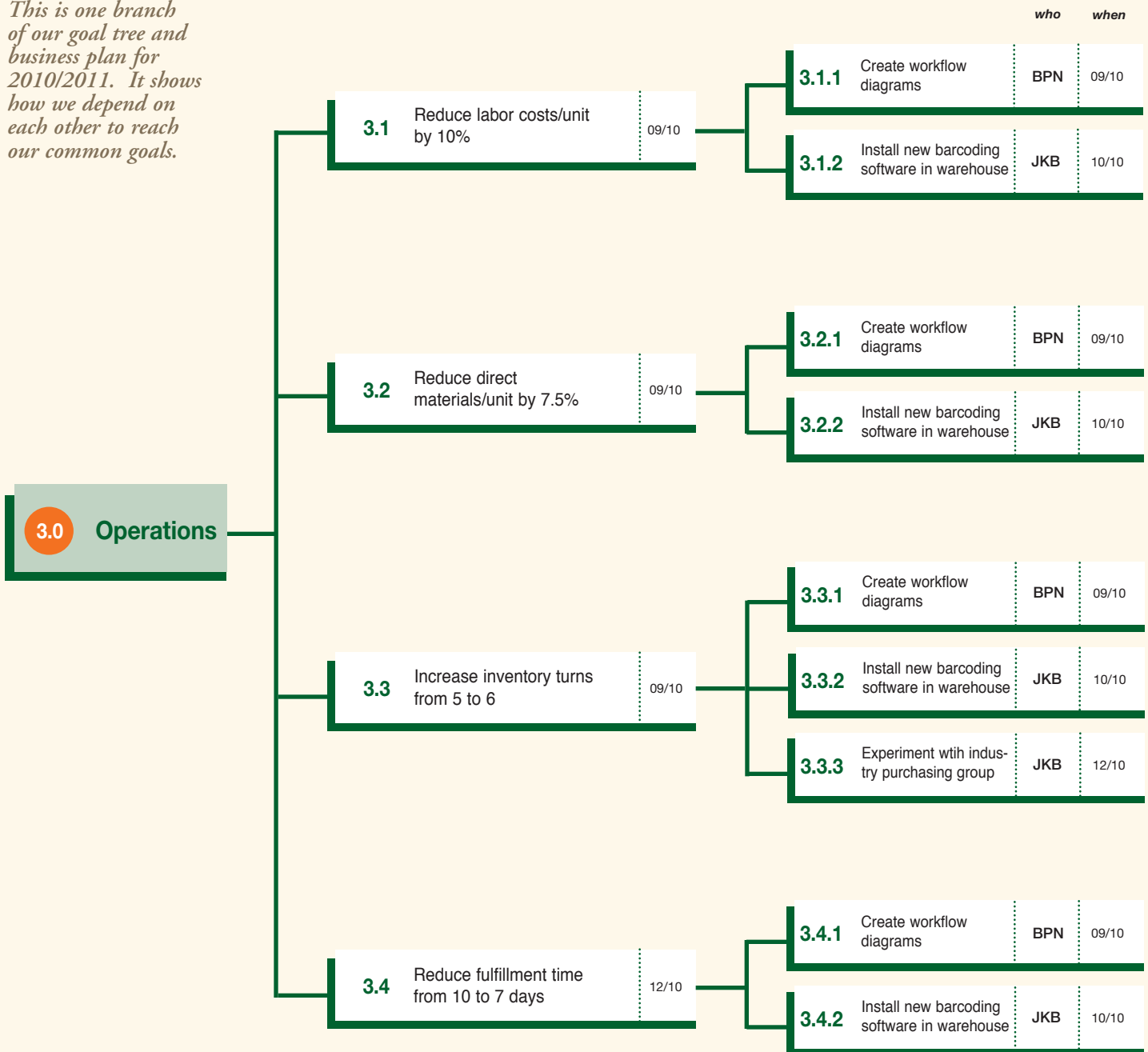



IT Goals

Tasks

*This is one branch of our goal tree and business plan for 2010/2011. It shows how we depend on each other to reach our common goals.*

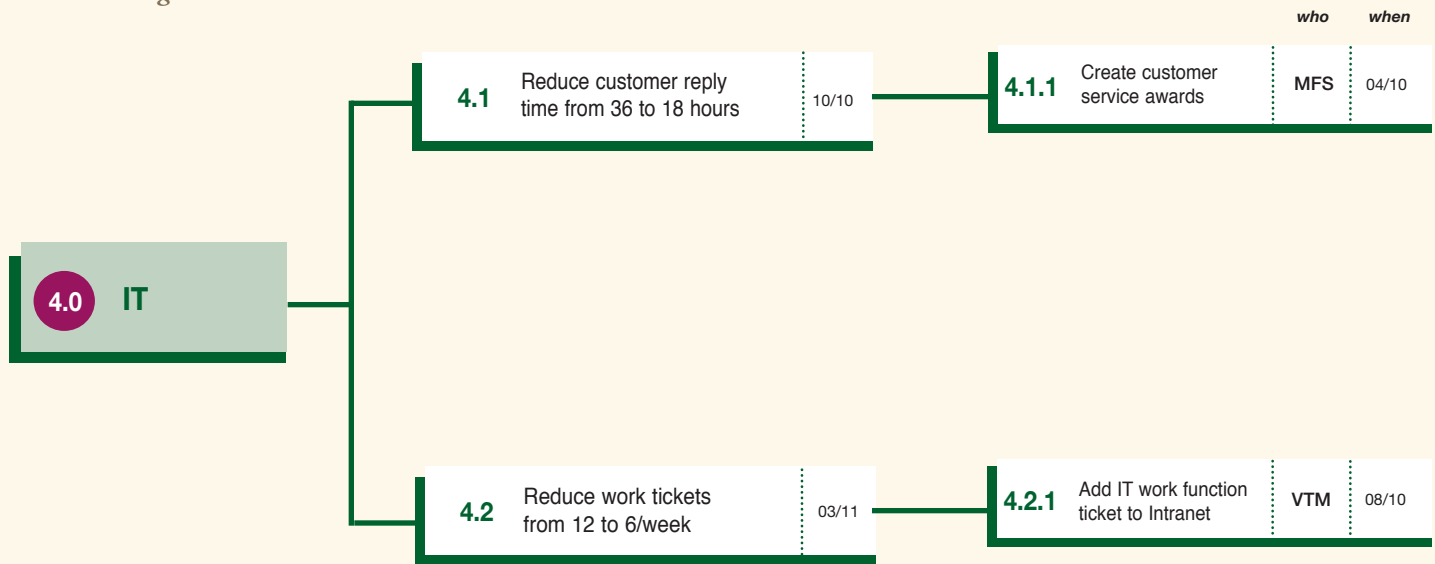



Human Resources Goals

Tasks

This is one branch of our goal tree and business plan for 2010/2011. It shows how we depend on each other to reach our common goals.

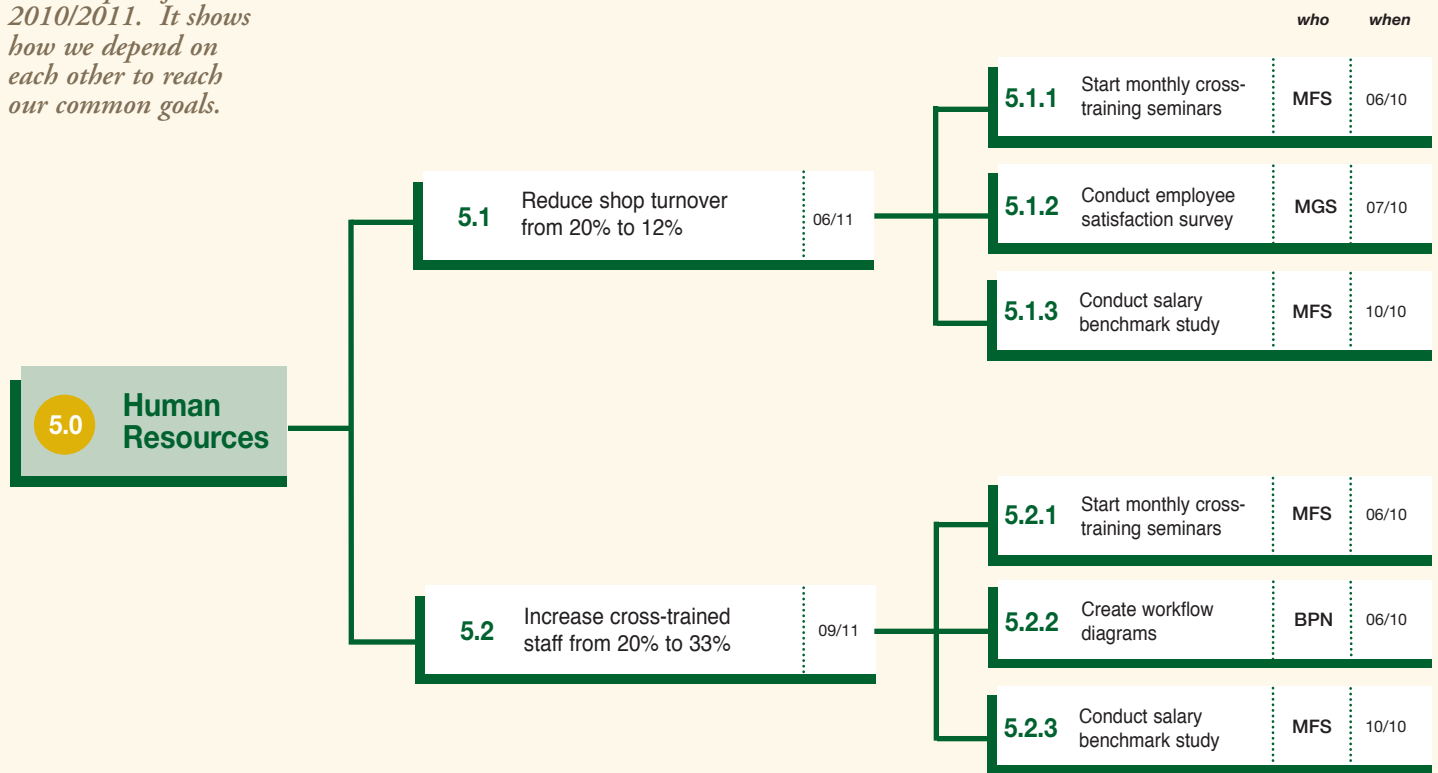



Finance Goals

Tasks

This is one branch of our goal tree and business plan for 2010/2011. It shows how we depend on each other to reach our common goals.

